

SLIPRING TYPE DD & ZDD

brush holders

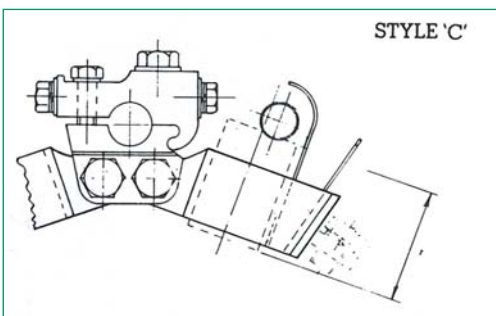
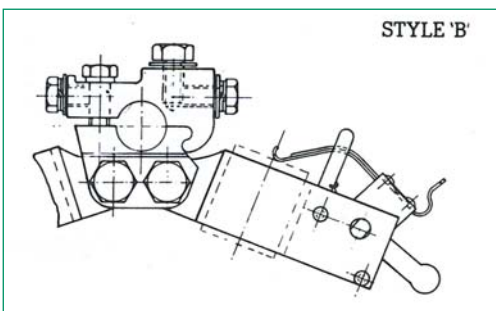
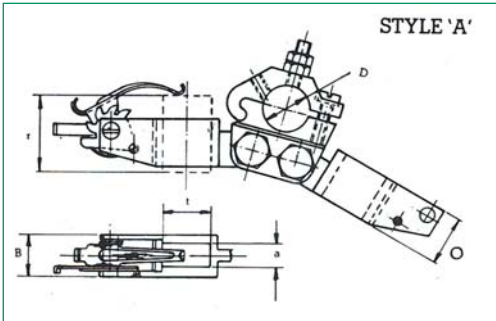

Slipring brush holder

Extruded brush boxes bolted to common clamp.
Adjustable to suit a wide range of slip ring sizes.

Pressure fingers are actuated by stainless steel springs, adjustable by ratchet and lever.

Constant force holders for slip rings

Extruded or cast boxes on common clamp.
Adjustable to suit a wide range of slip ring sizes.

Constant force springs on a stainless steel carrier.

Finish - tinplate

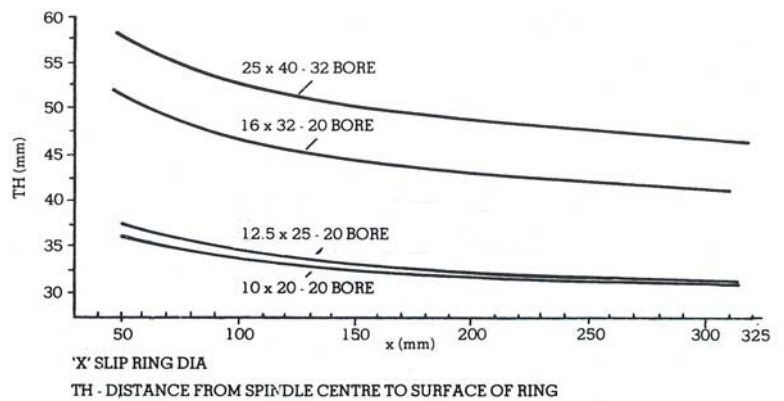

Type number	Type number	t	a	r	O	D	B	Style
DD0612M/2002		20	10	25	19	19	17.5	A
DD0816M/2001		25	12.5	25	19	20	17.5	A
DD1020M/2001		32	16	40	32	20	24	B
DD1625M/2002		40	25	40	32	32	32	B
Constant force	(with lugs)							
ZDD0612M/2001	N/A	20	10	32	20	16	16	C
ZDD0816M/2001	N/A	25	12.5	40	25	20	17.5	C
ZDD1016M/2001	ZDD1016M/2010	25	16	40	25	20	21	C
ZDD1020M/2002	ZDD1020M/2004	32	16	50	32	20	25	C
ZDD1220M/2002	ZDD1220M/2003	32	20	50	32	25	25	C
ZDD1620M/2002	ZDD1620M/2003	32	25	50	32	25	32	C
ZDD1224M/2001	ZDD1224M/2002	40	20	50	32	25	25	C
ZDD1624M/2001	ZDD1624M/2002	40	25	50	32	25	32	C
ZDD2024M/2001	ZDD2024M/2002	40	32	50	32	25	37	C

