

SELF CONTAINED

slipring assemblies

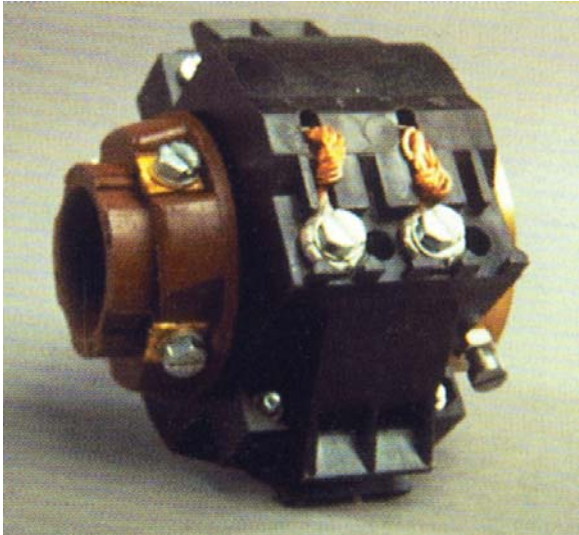

Morgan Industrial Carbon manufacture and stock a variety of self contained modular slipring units

Suited for machinery such as packaging machinery, data transfer and signalling applications.

Technical specifications

- 4, 8 and 12 ring units
- 25 Amps per ring
- 500 Volt rating
- Maximum running speed 60RPM
- Mounting shaft 30mm diameter

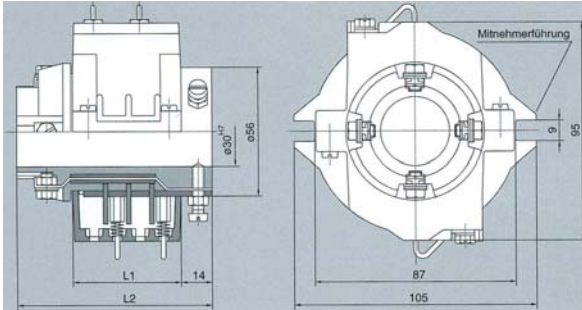

Type	Rings	L1	L2
F1196	4	47	84.5
F1876	8	94	135
F1876RH*	8	94	135
F4191	12	141	185

* Special version with rhodium rings and silver graphite brushes for data transmission applications

