

CANTILEVER FORCE BRUSH HOLDERS KPA radial type

Cantilever force KPA radial type holder

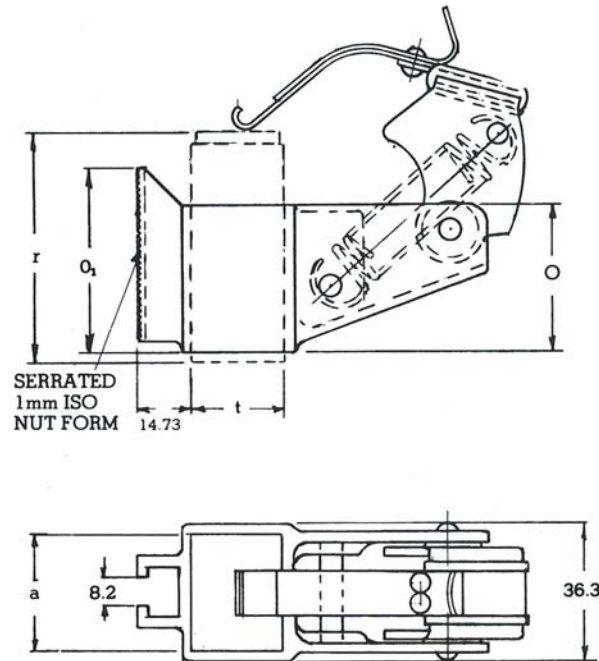

Type number	t	a	r	O	O1	GMS force	newtons
KPA2010m/1	16	32	64	40	40	1020	10.0
KPA2012m/1	20	32	64	40	40	1220	11.96
KPA2016m/2	25	32	64	40	50	1800	17.65
KPA2020m/1	32	32	64	40	50	2300	22.55

Suitable for heavy duty DC mill motors, large industrial machines and traction applications

Construction

Brass die-casting or extruded brass

Pressure finger with neoprene damping device to absorb vibration and to insulate the finger blade. Helical steel spring giving virtually, a constant force over the wearing length of the carbon brush.

Finish – natural lacquered

