

MECHANICAL CARBON

carbon vanes



Morgan Industrial Carbon – carbon vanes are made in a range of carbon materials (carbon/graphite, metal impregnated carbon/graphite and resin bonded graphite) to meet many different application requirements.

All Morgan Industrial Carbon grades retain the basic properties, which make carbon unique as an engineering material, and particularly suited for vanes that may operate in conditions beyond the limits of other materials.

Carbon vanes are self-lubricating, and therefore ideal for pumps handling liquids whose lubricating properties are poor such as petrol. They can also operate unlubricated in compressors to deliver air or gas uncontaminated by lubricating oil or grease, in which case the carbon gives a fine polish to the cylinder wall which reduced the wear rate of the vane after bedding in to almost negligible proportions.

Applications

The applications where carbon vanes are being used are extensive. Typical of these are:

- Dry running rotary compressors and vacuum pumps
- Mobile compressors fitted to bulk delivery tankers
- Printing machinery
- Spray paint equipment
- Packing machinery
- Food processing equipment
- Wet running vane pumps and meters
- Automotive diesel fuel pumps
- Drink vending machines
- Fuel tanker meters



MECHANICAL CARBON

carbon vanes

Carbon vanes are chemically inert and non toxic and cannot contaminate the liquid or gas being handled. They can safely be used in food processing equipment and in other fields where purity is essential.

Carbon vanes are totally unaffected by water, most acids, alkalies or oil solvents such as petrol or paraffin. In these conditions, the liquid can reduce friction and wear by providing lubrication between vane and rotor slots and vane top and cylinder wall.

One of the most important requirements for vane materials is high mechanical strength. Carbon vanes meet this requirement. Their strength is indicated by the pressures regularly handled which range from 3.2 kgf/cm (454lbf/in²) down to high vacuum conditions, with peripheral speeds up to 12.7 m/sec (2500 ft-min).

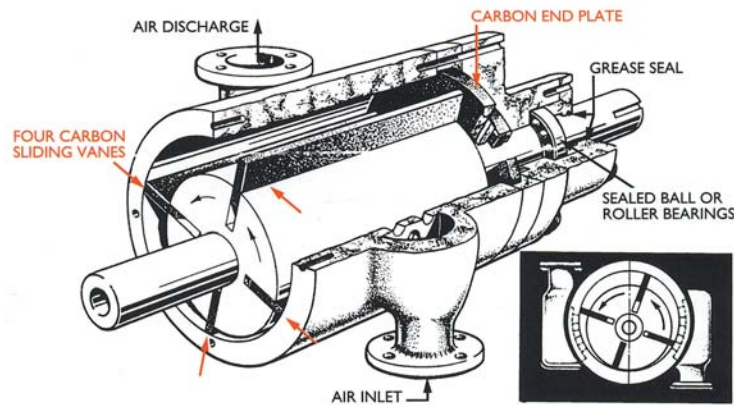

TYPICAL ROTARY VACUUM PUMP

Cylinder materials and design

It is important to use the correct cylinder material for operation with carbon vanes. Where possible a corrosion resistant metal should be used, and for optimum results this should be as hard as possible. Suitable materials are;

- Ni-resist cast iron
- Cast iron , minimum of 220 Brinell
- Meehanite cast iron
- Hard stainless steel, minimum of 420 Brinell
- Nitralloy steel, fully hardened
- Hard chrome plating 0.13 to 0.25mm
- Hard alloy, ie cast aluminium, aluminium oxide coated

The cylinder wall should be fine ground and honed, if possible, to a surface finish of 15/25 microinch CLA

Rotor materials

This should also be of corrosion resistant material. Each slot should be well finished and free from any surface roughness.

Information required

To assist in the manufacture of required vanes, please assist by completing the required relevant data below

Vanes _____
 Width of vane _____
 Depth of vane _____
 Thickness of vane _____
 Material being pumped _____



Head Office-Sydney
 21 Amour St
 Revesby NSW 2212
 T: 02 9772 5600
 F: 02 9774 5677
 E: sales@morgancarbon.com.au

Melbourne
 5/23-25 Bunney Rd
 South Oakleigh VIC 3167
 T: 03 9551 2377
 F: 03 9551 2177
 E: mel@morgancarbon.com.au

Perth
 4/195 Bannister Rd
 Canning Vale WA 6155
 T: 08 9456 3711
 F: 08 9456 3716
 E: per@morgancarbon.com.au

Brisbane
 34 Aerodrome Rd
 Caboolture QLD 4510
 T: 07 5433 7100
 F: 07 5432 4899
 E: bri@morgancarbon.com.au

Auckland
 5c Clemway Place
 PO Box 21195
 Henderson Auckland 1231 New Zealand
 T: 09 836 9220 / 0800 CARBON (0800 227 266)
 F: 09 836 9129 / 0800 4 BRUSH (0800 427 874)
 E: sales@morgancarbon.co.nz