

# SPARK PLUG TYPE

## brush holders

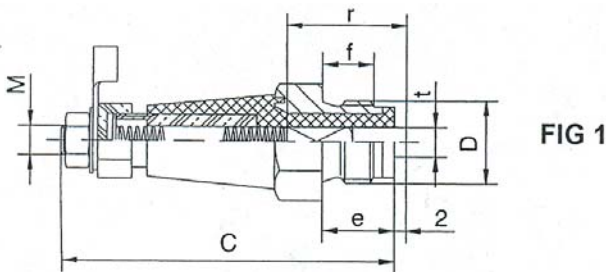

Morgan Industrial Carbon supply a wide range of “spark plug” type holders to suit magnetic clutch applications. Brush design used for dry running applications are of copper graphite composition, whereas wet running types require oil mist or oil lubrication and are constructed of a brass gauze brush design.



SW

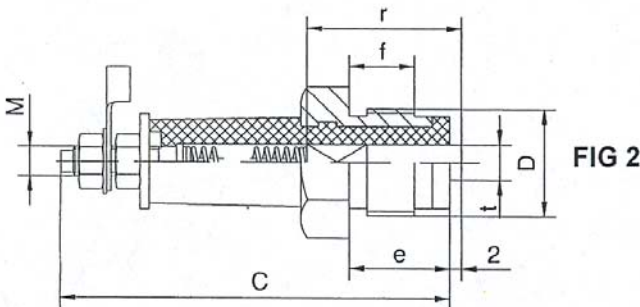

SW

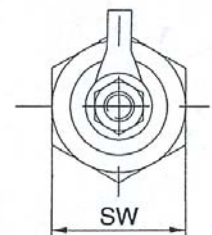
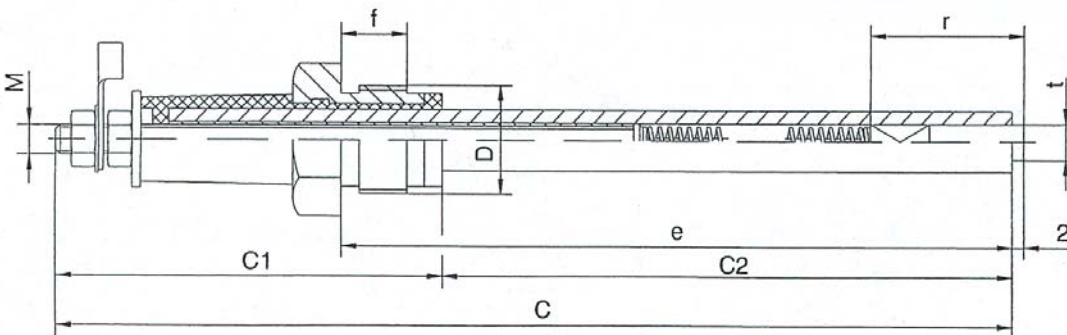

SW



# SPARK PLUG TYPE

## brush holders



### Brush holder

Type number	t ∅	r	C	C1	C2	D	SW	e	f	Stud type	Fig number
RKT 450 M14	4	20	50	-	-	M14 X 1.5	17	12	7	M4	1
RKN 450 M14	4	20	50	-	-	M14 X 1.5	17	12	7	M4	1
RKT 555 M14	5	20	55	-	-	M14 X 1.5	17	12	8.5	M5	1
RKN 555 M14	5	20	55	-	-	M14 X 1.5	17	12	8.5	M5	1
RKT 667 M16	6	26	67	-	-	M16 X 1.5	19	20	11	M5	2
RKN 667 M16	6	26	67	-	-	M16 X 1.5	19	20	11	M5	2
RKT 6145 M16	6	26	145	67	78	M16 X 1.5	19	98	11	M5	3
RKN 6145 M16	6	26	145	67	78	M16 X 1.5	19	98	11	M5	3
RKT 664 M18	6	26	64	-	-	M18 X 1.5	22	17	11	M5	2
RKN 664 M18	6	26	64	-	-	M18 X 1.5	22	17	11	M5	2
RKT 666 M18	6	26	66	-	-	M18 X 1.5	22	19	11	M5	2
RKN 666 M18	6	26	66	-	-	M18 X 1.5	22	19	11	M5	2
RKT 6145 M18	6	26	145	64	81	M18 X 1.5	22	98	11	M5	3
RKN 6145 M18	6	26	145	64	81	M18 X 1.5	22	98	11	M5	3
RKT 871 M18	8	30	71	-	-	M18 X 1.5	22	20	14	M5	2

RKT denotes brush holder for dry running conditions  
RKN denotes brush holder for wet running conditions

### Brush to suit

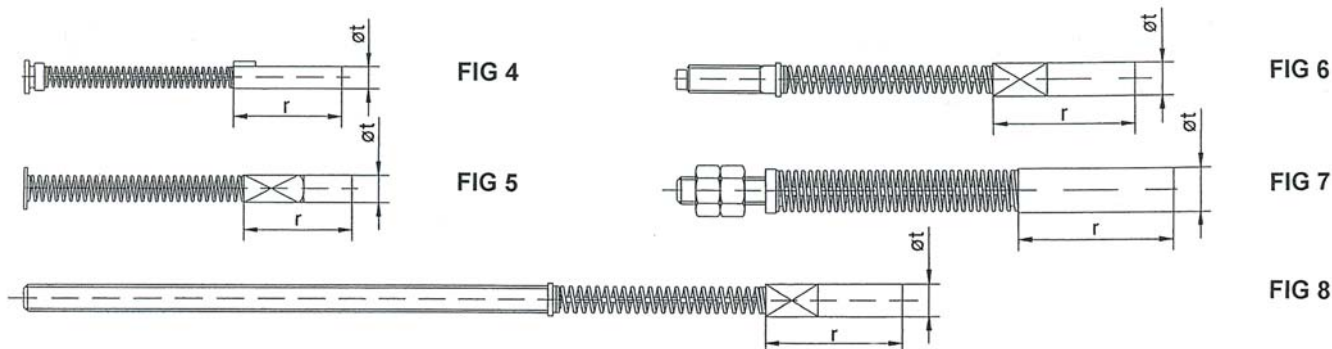

Type number Dry running	Wet running	Suits brush holder type	t ∅	r	Brush dim (A)	Max surface speed M/Sec	Brush force gms	Brush wear length	Fig number
100.01572.00		RKT 450 M14	4	20	2	40	300	12	4
	F1036	RKT 450 M14	4	20	3	20	800	12	4
100.01970.00		RKT 555 M14	5	20	4	40	400	12	5
	F1642/1	RKT 555 M14	5	20	6	20	1450	12	5
100.02371.00		RKT 667 M16 RKT 664 M18 RKT 666 M18	6	26	4	40	400	18	6
	F4363	RKT 667 M16 RKT 664 M18 RKT 666 M18	6	26	6	20	1450	18	6
100.02485.00		RKT 6145 M16 RKT 6145 M18	6	26	4	40	400	18	8
	F4364	RKT 6145 M16 RKT 6145 M18	6	26	6	20	1450	18	8
100.01495.00		RKT 871 M18	8	30	10	30	500	20	7



**Head Office-Sydney**  
21 Amour St  
Revesby NSW 2212  
T: 02 9772 5600  
F: 02 9774 5677  
E: sales@morgancarbon.com.au

**Melbourne**  
5/23-25 Bunney Rd  
South Oakleigh VIC 3167  
T: 03 9551 2377  
F: 03 9551 2177  
E: mel@morgancarbon.com.au

**Perth**  
4/195 Bannister Rd  
Canning Vale WA 6155  
T: 08 9456 3711  
F: 08 9456 3716  
E: per@morgancarbon.com.au

**Brisbane**  
34 Aerodrome Rd  
Caboolture QLD 4510  
T: 07 5433 7100  
F: 07 5432 4899  
E: bri@morgancarbon.com.au

**Auckland**  
5c Clemway Place  
PO Box 21195  
Henderson Auckland 1231 New Zealand  
T: 09 836 9220 / 0800 CARBON (0800 227 266)  
F: 09 836 9129 / 0800 4 BRUSH (0800 427 874)  
E: sales@morgancarbon.co.nz